

CONTROL ACTUATOR
INSTRUCTION MANUAL
CA-01H ~ CA120H



SEG Shin Hwa Eng Co., Ltd

Contents

1	Product description	3
1-1	Overview	3
1-2	General matters	3
1-3	Characteristics	3
1-4	Standard specification	4
1-5	Terminology of CA	4
2	Installation	5
2-1	Structure	5
2-2	Transport and Installation	5
(1)	Transport	5
(2)	Place for Installation	5
(3)	Installation	5
(4)	Caution for Installation of Control Actuator	6
(5)	How to install control actuator	6
(6)	Matters to check before operation	6
2-3	Limit switch adjustment (CA01H~CA10H FB, AB option type)	6
(1)	Position limit switch adjustment method	6
(2)	Torque limit switch	7
2-4	Limit switch adjustment (In RB, SB option)	8
(1)	Position limit switch adjustment method	8
(2)	Torque Limit Switch	9
2-5	Adjustment of Resistance (Potentiometer:Jp-30)	10
2-6	Adjustment of Current Transmitter	10
2-7	Adjustment of balancing relay (SBR-10)	12
2-8	How To adjust STP-07 (Indicator)	14
3	Maintenance	15
3-1	Troubleshooting	15
4	Basic Circuit Diagram (Standard)	16

1 Product description

1-1 Overview

- (1) The Control Actuator is made by combining all components such as a decelerator, motor, limit switch, overload torque switch, current transmitter, manual handle instrument, and remote control box. It is standardized for precise operation.
- (2) This product simply opens and closes by remote control a damper or a valve with bad conditions such as a high position, a high temperature, and much dust. Thus, it is the most ideal for the latest factory facilities which are advanced and complex.
- (3) The Control Actuator is operated by an electric signal communication, and can perform a servo control with a computer or a controller. It is an effective equipment to save energy and reduce costs in automatic control of temperature, pressure, and flux.
- (4) It is an electric controller, whose maintenance and control are easy. It has a high reliability and has been broadly used in industries such as iron manufacture, cement, chemical factories, and fans and boilers for power plants for a long time.

1-2 General matters

- (1) The Control Actuator is to open and close a damper, valve, or the like by In addition, it can make a proportional operation in accordance with a received signal if combined with a potentiometer.
- (2) Thanks to its special gear structure, it is small and easy to install.
- (3) Every type of this product has a torque switch, and uses a continuous rating motor.
- (4) It has a dustproof, drip proof structure.

1-3 Characteristics

- (1) The Control Actuator uses the principle of epicycle for the gear structure, and it can perform the normal operation and the reverse operation of the manual handle even when it is operating with the motor with power supply.
Even while it is being electrically driven, you can randomly operate the manual handle with no mechanical burden.
As well, it is designed to be self-locking by using the number of teeth of the worm and the wheel, and has a structure where manual operation can be easily done immediately when an emergency occurs.
- (2) The internal structure has the machine unit and the electric unit separated from each other. They are completely airtight to give no impact on the electric unit.
- (3) The type with the Local Control Box attached has an automatic-manual converting control box attached as one body.
It can easily convert to automatic and manual.
- (4) Since a torque switch, which is a mechanical overload protection device, is mounted, when a load greater than the rated output is applied, the power supply is blocked to prevent the product from being damaged.

1-4 Standard specification

Structure	: Full-shut, outdoor type	Humidity	: 85% or lower
Operating angle	: 90°	Standard painting color	: Munsell 7.5BG 6/1.5
Ambient temperature	: -20°C~60°C	Input signal	: Contact point signal
Operating speed	: 60sec/90°		: Current signal (4~20mA DC)

Ex) HAB Type

MODEL	Rated Torque (kgf-m)	Timing 50/60Hz (sec/90°)	Motor Power(W) (Phase)	Rating (min)	Voltage (V)	Frequency (Hz)	Weight (kg)	Rev. of Manual Handle (turn/90°)	Handle oper. force (kg)
CA-01H	15	36/30	25(Φ1/Φ3)	30	Φ1 220 / Φ3 440	50/60	23	22	9
CA-02H	25		25(Φ1/Φ3)				28	22	13
CA-05H	50		60(Φ1/Φ3)				71	24	16
CA-10H	100		90(Φ1/Φ3)				87	72	13
CA-20H	200		200(Φ3)				110	236.2	8
CA-40H	400	42/35	400(Φ3)	440	50/60	230	260	15	
CA-80H	800		750(Φ3)			230	236	17	
CA-120H	1200		1500(Φ3)			230	303	19	

1-5 Terminology of CA

CA - 01 H □ □
<div style="display: flex; align-items: flex-start;"> <div style="flex: 1;"> </div> <div style="flex: 2; padding-left: 20px;"> <p>Model name : Control Actuator</p> <p>Category of output torque ex: 01 = 15kgf-m , 10 : 100kgf-m</p> <p>Manual handle : Every type of the CA series has a manual handle attached</p> <p>Control method S : On-Off Control R : Feed Back Signal 0~1kΩ F : Feed Back Signal 4~20mA DC A : Auto Type (Balancing Relay) (Command Signal 4~20mA) (Feedback Signal 4~20mA)</p> <p>With local box attached : B</p> </div> </div>

2 Installation

2-1 Structure

When you maintain and check the Control Actuator, please refer to the below diagram.

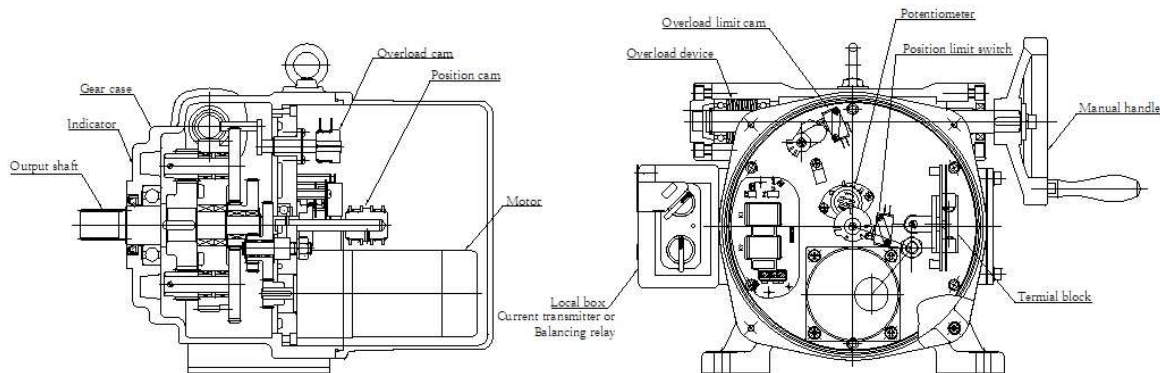

Fig.-1. Control Actuator structure

2-2 Transport and Installation

- (1) Transport
 - When you transport this product, please avoid an accident such as fall and impact.
- (2) Place for Installation
 - There is no special limit in the place for installation of the Control Actuator, but if it is exposed to an environment with bad conditions for a long time, you had better use a proper protection device.
 - As well, you had better secure proper space around the Actuator for maintenance and repair.
- (3) Installation
 - When you install the Control Actuator in a mounting place selected in advance for installation, firmly fixate the Actuator with four bolts.
 - Connect the lever arm and the corresponding lever.
 - The operation angle is correctly adjusted before delivery, and you do not need to adjust it. If you need to adjust it:
 - ① Give a current signal (a contact point signal in case of opening/closing control and angle control) to put the Actuator in a complete opening (or closing) position.
 - ② Turn off the power supply, and separate the cover on the rear surface of the Actuator from the main frame. Here, avoid giving a damage to the gasket.
 - ③ Readjust the Position Limit Switch to fit the contact point.
(Refer to Clause 7 later for how to adjust the Limit Switch.)
 - ④ Here, check if the needle of the indicator is in the complete opening (or closing) position before adjusting.
 - ⑤ Fit the gasket and the cover, close them, and tighten with a bolt.
 - Please consult the manufacturer when changing the direction of rotation of the output shaft

(4) Caution for Installation of Control Actuator

- ① Never give an impact on the output axis of the product. It is a slow equipment with the total operation time of 30-60 seconds, but a momentary torque by shock makes a great vibration and can give a damage to the gear, motor, or the like.
- ② You must the axis lines of the output axis of the product and the corresponding axis parallel and on the same line as much as possible.
If the axis lines are not parallel or not on the same line, a load can be applied to the output axis of the product, causing a shorter life and a damage to a connecting link.

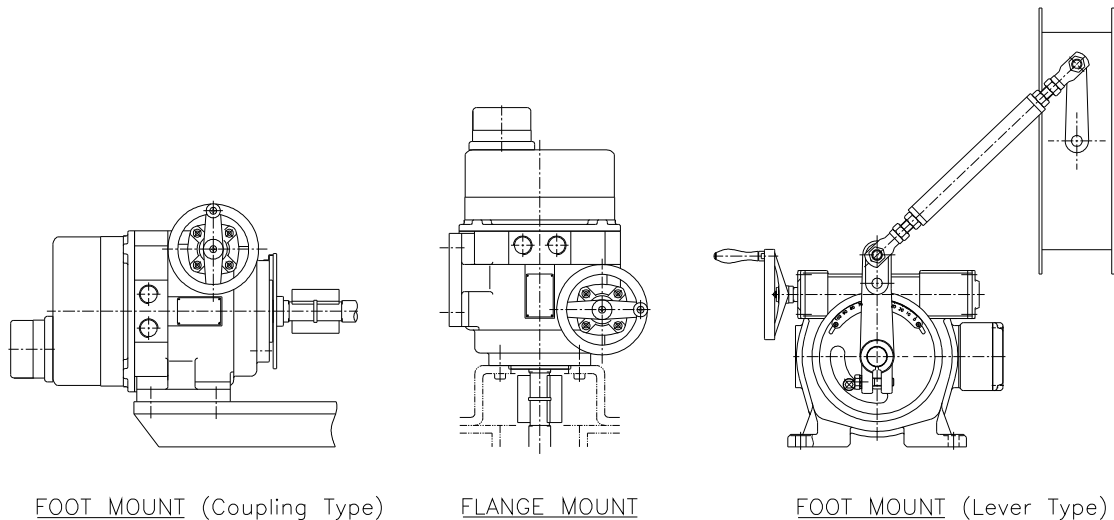

Fig.-2. How to install CA

(6) Matters to check before operation

- ① Check if the Control Actuator is firmly installed on the device to control.
- ② Check if the damper or the valve smoothly operates. In addition, check if the subject to control is completely opened or closed and if it receives an excessive pressure.

2-3 Limit switch adjustment (CA01H~CA10H FB, AB option type)

(1) Position limit switch adjustment method (based on clock direction in view of output shaft)

- ① Please note "Fig-1. CA structure" and check limit switch position.
- ② In "Fig-3. Limit switch and cam arrangement" upper horse-shoe sensor LS2P is close sensor and below horse-shoe sensor LS1P is open sensor.
- ③ Horse-shoe sensor LS1P and LS2P are available position control and signal control respectively.
- ④ In order that dial gauge meet into 0% exactly, after loosing ㉑needle fixed bolt and adjust ㉒needle (Note Fig-4)

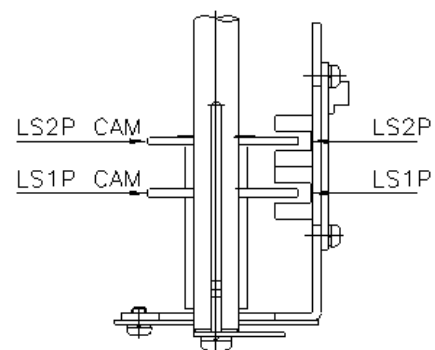

Fig-3. Limit switch and cam arrangement

⑤ Adjustment of limit switch (LS1) for clock direction position control.

When dial gauge is positioned in 0%, please note "Fig-5 Limit cam adjustment (Close)" use flat screw driver, LS2P CAM should be rotated slightly into arrow direction and matched until LS2 lamp is on.

⑥ Upon setting LS2P, signal control shall be automatically matched.

⑦ Adjustment of limit switch (LS1) for counter-clock direction position control.

When dial gauge is positioned in 100%, the "Fig-6. Limit cam adjustment (Open)", LS1P CAM should be rotated slightly into arrow direction and matched until LS2 lamp is on.

⑧ Upon setting LS1P, signal control shall be matched automatically.

⑨ After adjusting limit switch cam, tighten upon bolt and cam should be fixed into cam shaft. Check the stop position by running the actuator electrically, and repeat the above process if the stop position is incorrect

<Inside indicator for HAB Type>

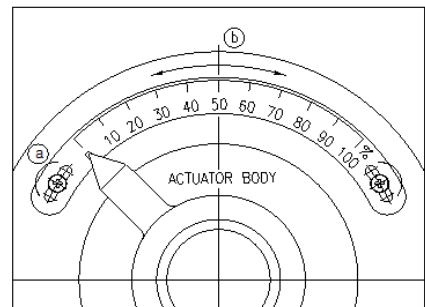

Fig-4. Adjustment process of dial gauge

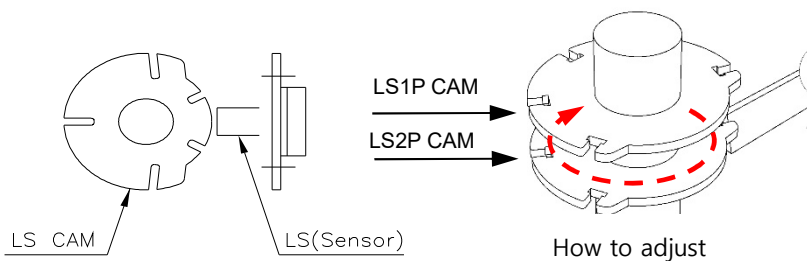

Fig-5. Adjustment of limit cam (close)

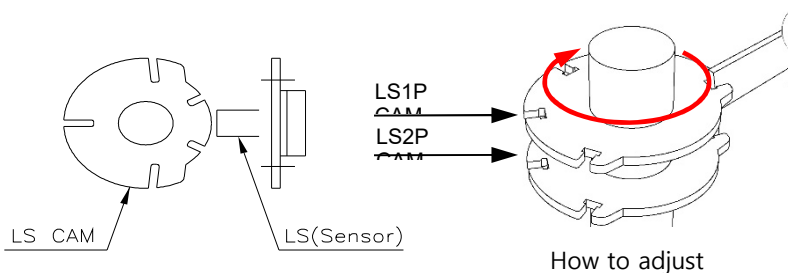

Fig-6. Adjustment of limit cam (open)



(2) Torque limit switch

- ① Do not operate randomly because it was adjusted when dispatching our factory.
- ② In standard mode, it is normal condition when rated torque switch LSF lamp and LSR lamp are off.



Fig-7. Torque limit switch lamp

2-4 Limit switch adjustment (In RB, SB option)

(1) Position limit switch adjustment method (In viewing of output shaft, it is based on clock direction-Open)

- ① In Fig-8, upon 2ea of limit switch LS2, LS4 are close direction (clock), below 2ea limit switch LS1, LS3 are open (Counter-clock) direction
- ② Limit switch LS1, LS2 are limit switch for position control and LS3, LS4 are limit switch for signal control.
- ③ It should be matched between dial gauge and damper operation direction.
For example if the damper direction is the closing direction, the dial gauge should be 0%
- ④ Actuator should be operated with complete close by auto and manual method.
- ⑤ Dial gauge should be matched into 0% exactly.
Unscrew set screw which is fixed to needle, and adjust it into 0%
- ⑥ Before adjustment of built-cam, loose cam edge's bolt (cam axis bolt from Fig-8.), keep condition that cam may be operated manually.

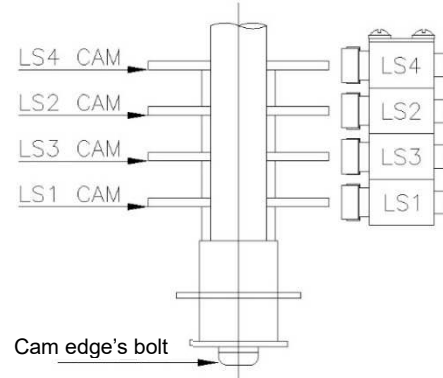

Fig-8. Arrangement of limit switch

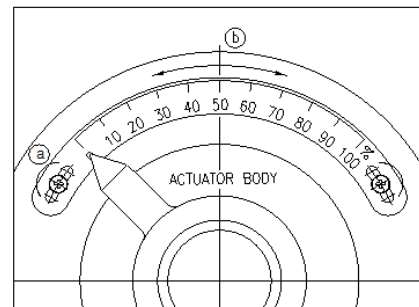

Fig-9. Procedure of adjusting the dial

- ⑦ The adjustment of limit switch(LS2) for close(clock direction) position control limit switch (LS2) should be slightly rotated into arrow direction and matched until there are happening on small sound and move into LS2 CAM with arrow (clock) direction by using flat screw driver when dial gauge indicates in 0% (note Fig-10,11)
(Please check whether stop position is correct or not after moving actuator with electric power supply.)
- ⑧ In Case that actuator stop position is not exact, please do above process 1-2 times repeatedly and match.

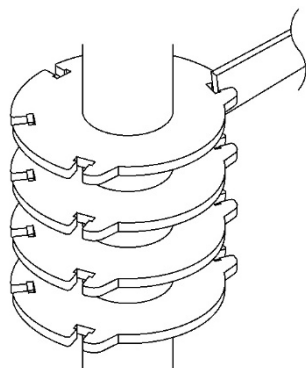

Fig-10. How to adjust Limit switch cam

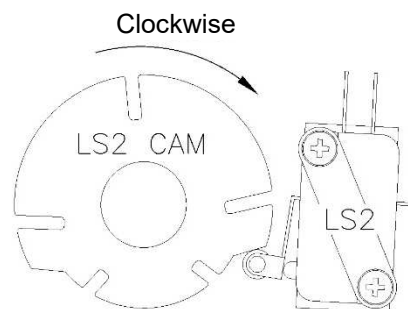

Fig-11. How to adjust limit switch cam2

- ⑨ Adjustment for open (CCW) direction limit switch (LS4) must move before control limit switch (LS2) as the Fig-12, with equal LS2CAM operation method to LS4 CAM.
(LS4CAM should be operated a little (around 3°~5°) in advance before LS2CAM)

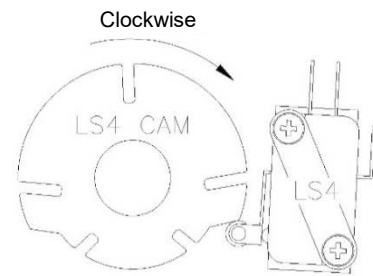

Fig-12. How to adjust limit switch4 cam

- ⑩ Open (CCW) direction position control limit switch (LS1) must be matched with arrow (CCW) direction so that limit switch sound may be click when indicator is 100%

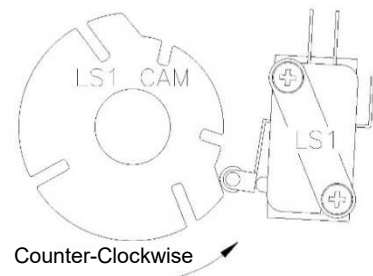

Fig-13. How to adjust limit switch1 cam

- ⑪ Adjustment for open (CCW) direction limit switch (LS3) must move before control limit switch (LS1), with equal LS1CAM operation method.
(It should be operated a little (around 3°~5°) in advance before LS1CAM.)

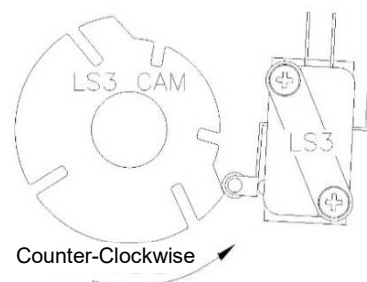

Fig-14. How to adjust limit switch3 cam

(2) Torque Limit Switch

- ① Owing that it was adjusted in our factory with rate torque base, so in site it should not be operated randomly.

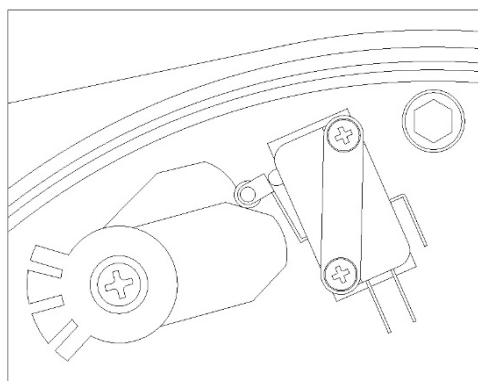

Fig-15. Torque limit switch

2-5 Adjustment of Resistance (Potentiometer:Jp-30)

- (1) Let the position check needle indicate 50% on the scale plate manually or electrically.
- (2) Hold the potentiometer with your hand and lift up.
And hold the "Adjustment plate" and rotate it so that the point is positioned as shown below (Fig-17.)
(Red point is marked on the "Adjustment plate")
- (3) After that, gently place the potentiometer on its original state
- (4) If positioned as shown below, 500Ω will be output
(The potentiometer's output is $0 \sim 1000 \Omega$)

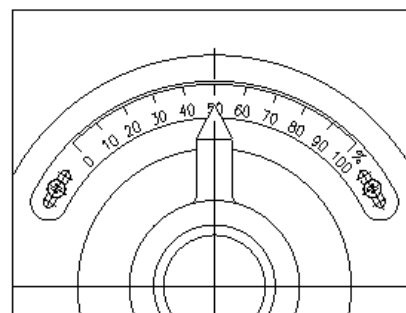

Fig.-16. Position of the scale plate

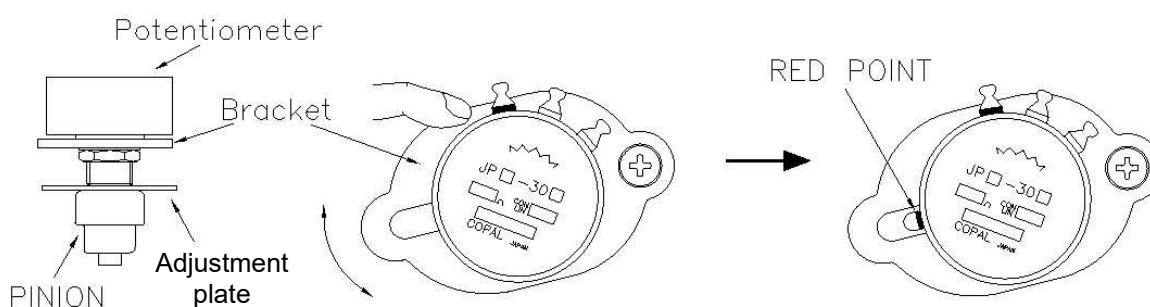

Fig.-17. Adjustment of resistance

2-6 Adjustment of Current Transmitter (CA-□□HF TYPE)

(Feedback Signal : DC 4 ~ 20 mA)

- (1) It is attached for "F" type of control method in "1-5 terminology" (Feedback signal : DC 4-20mA)
- (2) The Current Transmitter is a device that changes an input resistance signal into an output current signal.
- (3) Check if the power supply is turned on. When the power supply is on, it is normal for the LED to flicker with an interval of 0.5 seconds.
- (4) Control the Actuator to the position of completely closing automatically.
- (5) Finish the '2-5 Adjustment of Potentiometer', and check if the control is completely done.
If the LED flickers (with a shorter interval than 0.5 seconds), it means the resistance value is out of range
- (6) Measure the current between P1 and N1 of the terminal block, and check if it makes DC 4mA.
- (7) If DC 4mA is not made, push the R/I Converter Zero control switch for three to four seconds to set to DC 4mA.
- (8) And let the Actuator to the status of completely opening by turning automatically.
- (9) Measure the current between the P1 terminal and the N1 terminal to check if DC20mA is made.

- (10) If DC 20mA is not made, push the SPAN control switch on the R/I Converter for three to four seconds to set to DC20mA.
- (11) After actuator return to complete close position, measure current of P1 and N1, If DC4mA is not measured, repeat above process and if there is near to DC4mA, the adjustment is completed.
- (12) Repeat above (4)-(10) article over 2 times, adjust it, so that output value is near to it as possible.
- (13) Generally Zero , Span value is set as above method , but in case that there are difference among devices of installation place , please execute minute adjustment as following method .
- (14) value adjustment of ZERO, SPAN use MODE SWITCH and in that time KEY modification is as followings.

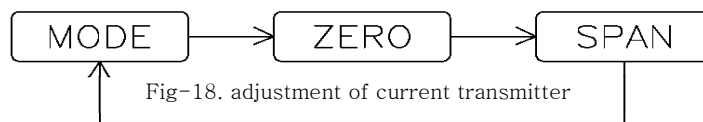

- (15) Under the condition that actuator is closed completely, push Mode switch one time and adjust with Zero/Span switch and do minute adjustment into 0% position (4mA).
- (16) After completing above (15) article process, actuator should be keep complete opening, and push Mode switch one time again and with Zero/ Span switch, execute minute adjustment into 100% position (20mA) by Zero/Span switch.
- (17) After completing minute adjustment, push Mode switch one time again, and escape.
(It should push 3 times, escape completely.)



Fig-19. Adjustment of current transmitter

2-7 Adjustment of balancing relay (SBR-10)

- (1) After setting dial gauge, limit switch, resistance, and then adjust SBR-10.
- (2) Put selector switch of local box into remote position.
- (3) push SW3 (Auto Scan) button switch for 3-4 seconds.
- (4) In this time, the auto lamp flickers and operates to set the output value (4-20mA DC). And the operating takes around 120-180seconds. (while the operating, do not operate arbitrary)
- (5) If the auto lamp flickers rapidly and actuator stops working, Please check whether resistance signal or resistance using angle is normal or not. (When the dial gauge is 50%, you can see red point on the resistance(potentiometer))
- (6) When the operating is completed, press the SW3 (Auto scan) button switch for 3~4seconds to complete the operation
- (7) A fault lamp flickers when the input signal is blocked or when the polarity(+,-) of the input signal changes or when the resistance is out of output(100~900Ω)
- (8) In normal case, you can adjust the balancing relay as above.
But if the installation site is deviated from the actuator, you can fine-tune it as shown below

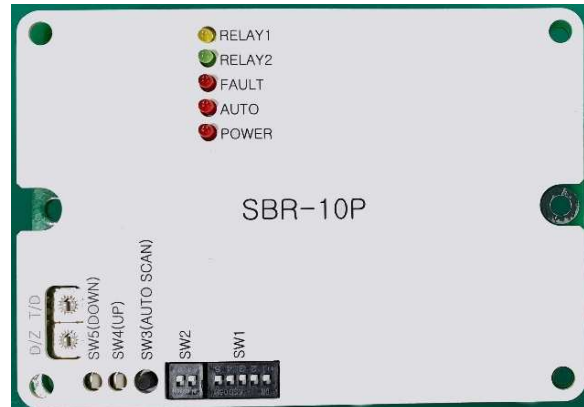
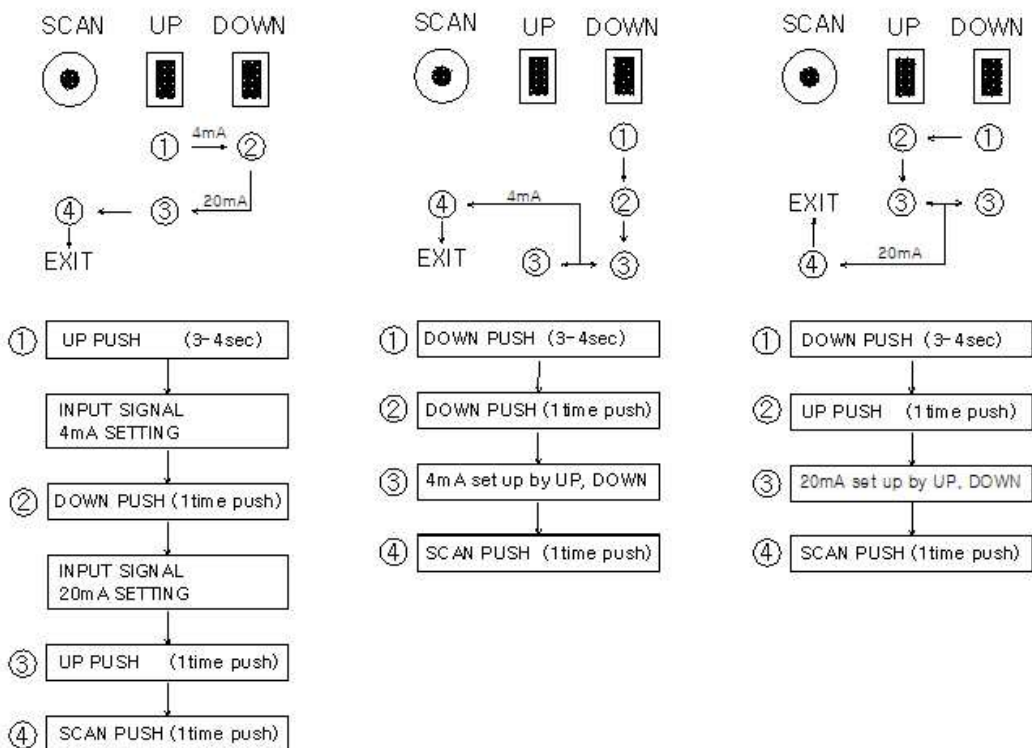

Fig.-19. Adjustment of balancing relay

INPUT SIGNAL 4~20mA SETTING FEED BACK SIGNAL 4mA SETTING FEED BACK SIGNAL 20mA SETTING



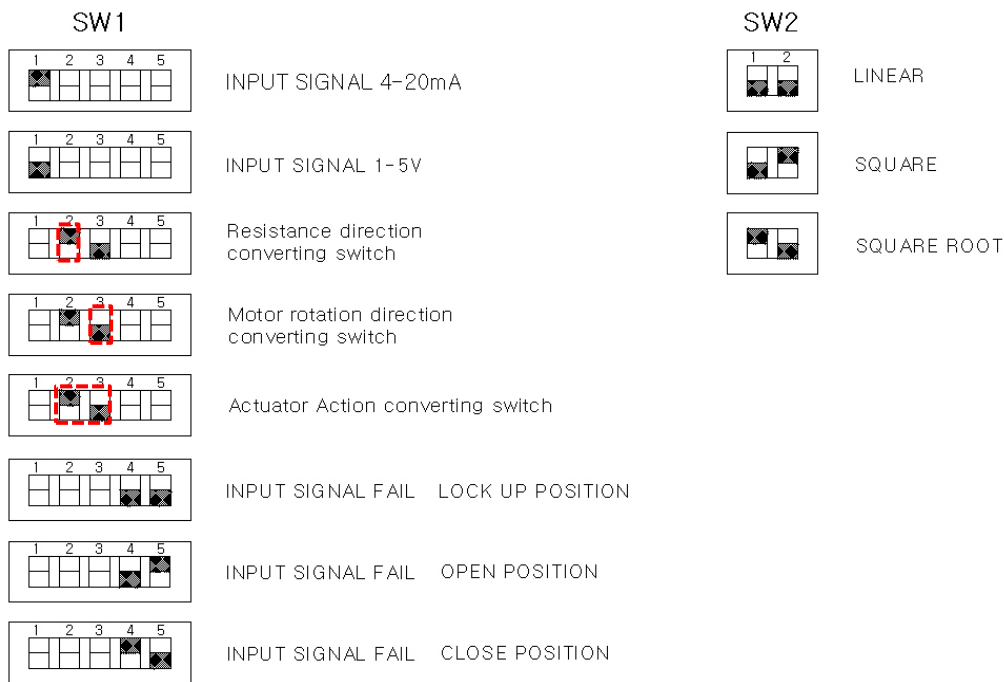
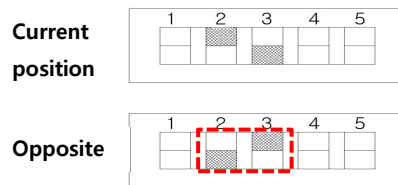

Fig.-20. Fine-adjustment of balancing relay

(9) If you want to convert the action direction of actuator, you can adjust it as shown below

- ① To change open and close, No.2 and No.3 switch must be change from its current position to the opposite position



- ② After that, short the two points of the marked switch "SW1" for 3 to 5seconds as shown.

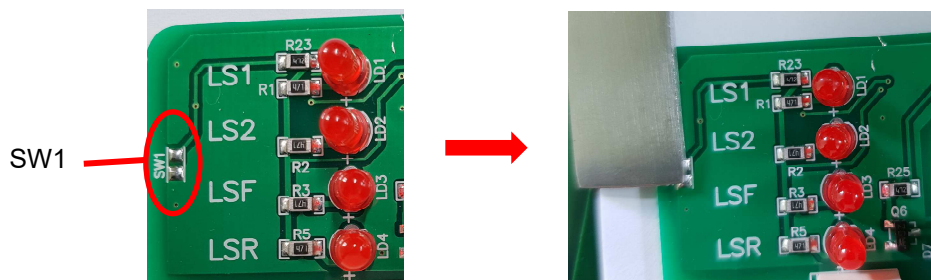

- ③ When LS1 and LS2 lamps flicker 3 to 5 times at same time, then LSF and LSR lamps blink 3 to 5 times at the same time, and then the LS2 lamps turn on and off, the action direction of actuator changes its direction from forward to reverse.
- ④ When LSF and LSR lamps flicker 3 to 5 times at same time, then LS1 and LS2 lamps blink 3 to 5 times at the same time, and then the LS1 lamps turn on and off, the action direction of actuator changes its direction from reverse to forward.

2-8 How To adjust STP-07 (Indicator)

- (1) When input signal is 4mA, in order to show output signal correctly, setting of indicator must be as followings.
 - Input signal should be adjusted into 4mA and push following picture's Switch-1 for 2~3 second.
 - The setting is complete when the "CL2" mark on LED plate flashes and returns normal state.
- (2) When input signal is 20mA, in order to show output signal correctly, setting of indicator must be as followings.
 - Input signal should be adjusted into 20mA and push following picture's Switch-2 for 2~3 second.
 - The setting is complete when the "OP2" mark on LED plate flashes and returns normal state.
- (3) If push Switch-1 or Switch 2 one times shortly, it is move into Zero and Span output signal setting mode.
Function of CL1 (OP1) is signal setting Mode which Actuator shows Zero / Span's normal position.
- (4) If pushing limit operation alarm signal switch-1 or switch shortly, it is Zero/Span output signal position setting, and after extinguishing CL1 /OP1, if indicator indicates "%"mark, use Up/Down switch and finish to set desired position(%), it will be automatically set after waiting for a while.
(In output setting mode, the function shall be converted into Switch-1= Down, Switch-2= UP)



Fig.-21. How to adjust STP-07

3 Maintenance

3-1 Troubleshooting

Symptom	Expected Cause	How To Repair	Note
The motor does not work.	Power is not supplied.	Supply power.	In case of three phase, check R, S, and T.
	The position control switch operates.	Reset to fit the scale plate.	
	The torque switch operates.	Remove the cause for overload.	Reset the switch. (Never randomly set.)
	The overload relay operates.	Remove the cause for overload.	Reset the set value. (Never randomly set.)
	The fuse is broken.	Replace the fuse.	In case of three phase
	The condenser is damaged.	Replace the condenser.	In case of single phase
	The brake does not work.	Replace the brake.	
The motor does not stop with the position control switch.	The motor makes a reverse rotation.	Connection is made with two lines among three lines changed.	It is in case of three phase, and it does not apply to the standard.
	The position control switch is changed.	The position control switches (LS1, LS2) are used by being changed.	It does not apply to the standard.
	The switch setting is defective.	Reset.	
	The switch is defective.	Replace the switch.	
When the torque switch operates, the motor does not stop.	The motor makes a reverse rotation.	Connection is made with two lines among three lines changed.	It is in case of three phase, and it does not apply to the standard.
	The torque switch is changed.	The position control switches (LSR, LSF) are used by being changed.	
	The switch is defective.	Replace the switch.	

4 Basic Circuit Diagram (Standard)

4-1 For Proportional Control (Using Balancing Relay & Potentiometer)

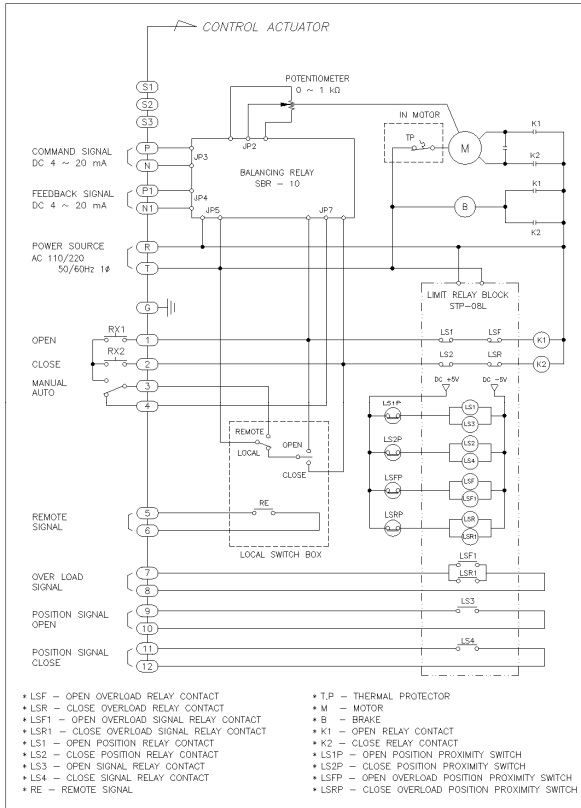

Single phase (Up to CA10H)

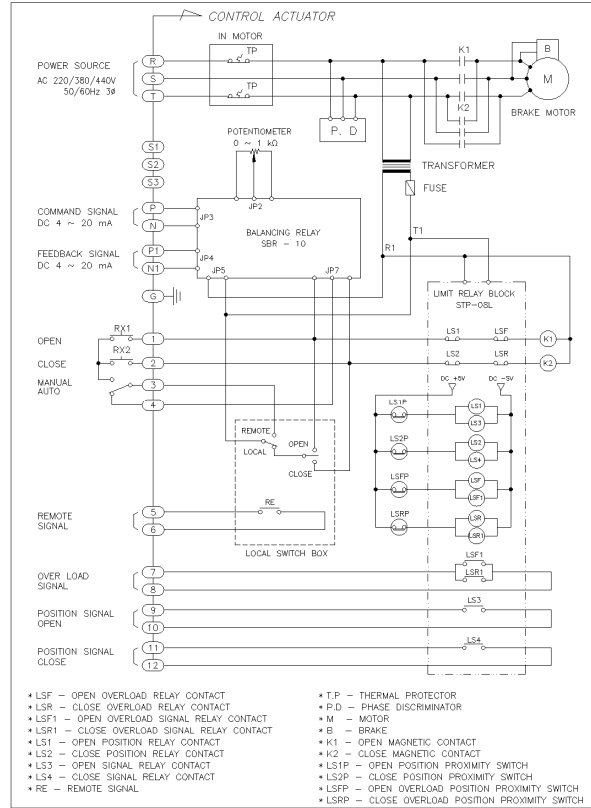

Three phase (Up to CA10H)

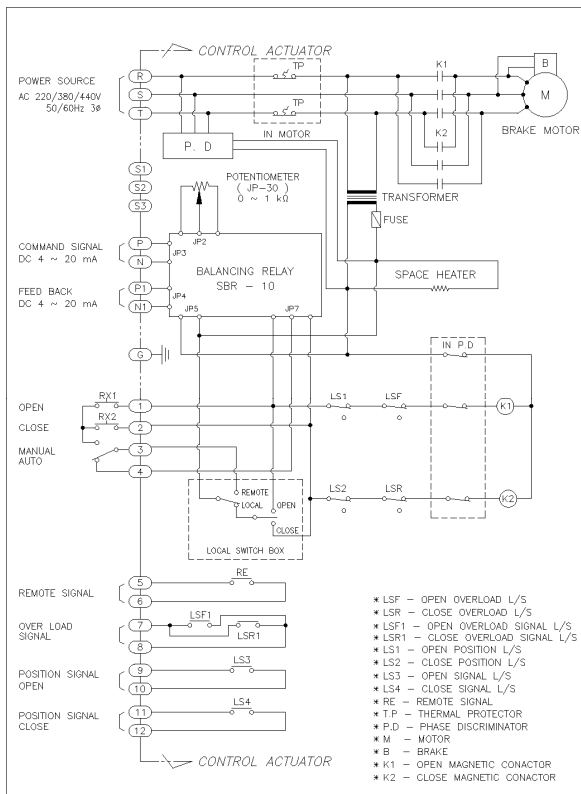

Three phase (More than CA20H)

4-2 For Opening Control (Using Current Transmitter & Potentiometer)

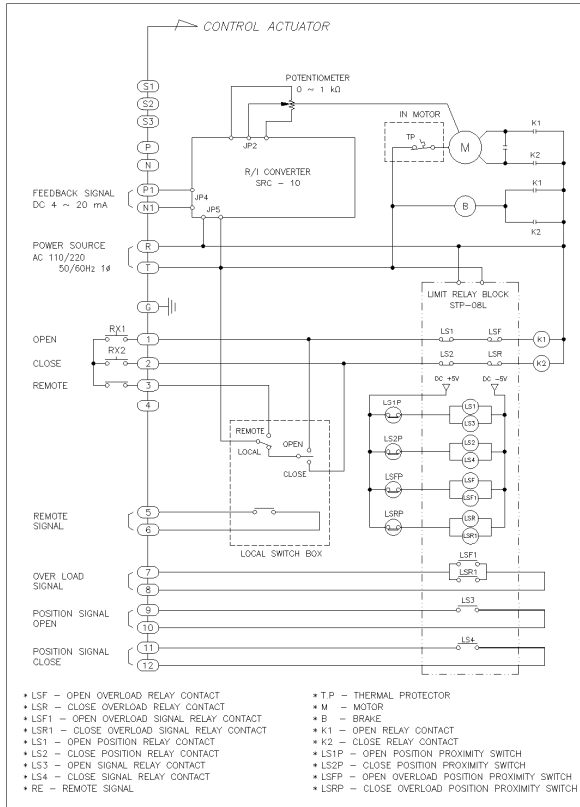

Single phase (Up to CA10H)

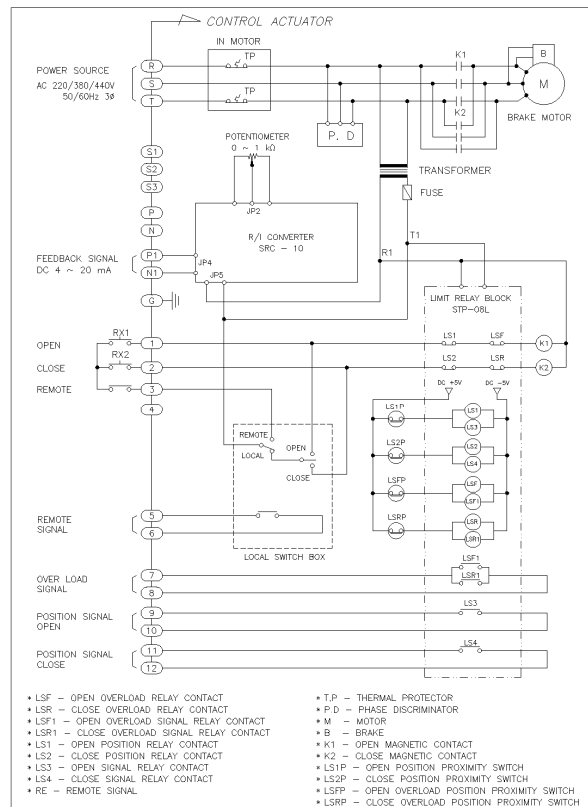

Three phase (Up to CA10H)

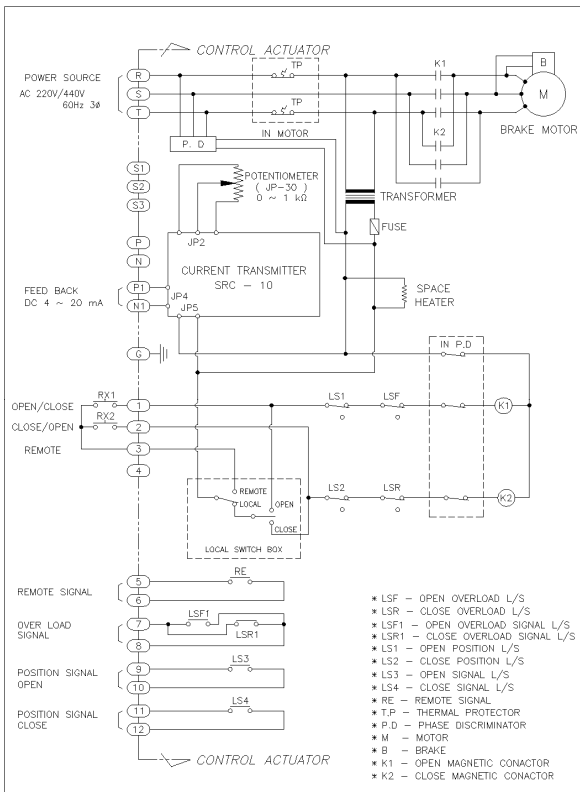

Three phase (More than CA20H)

4-3 For Opening Control (Using Potentiometer)

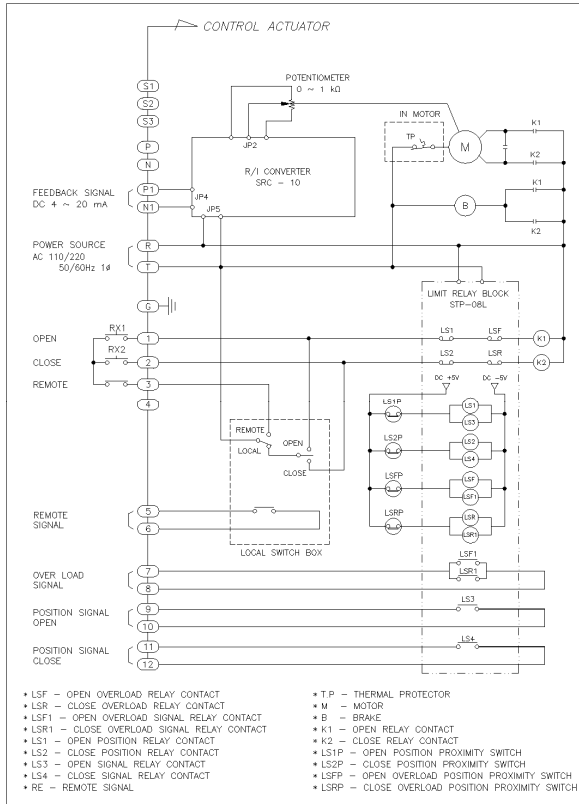

Single phase (Up to CA10H)

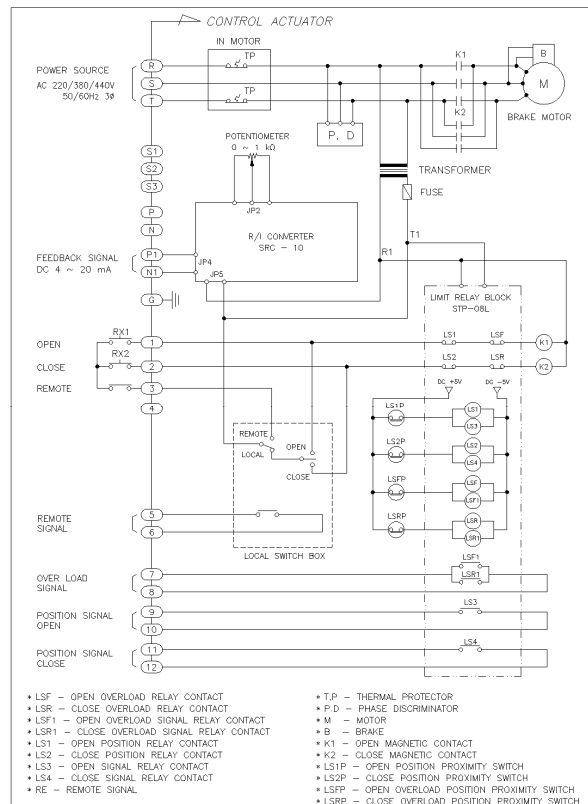

Three phase (Up to CA10H)

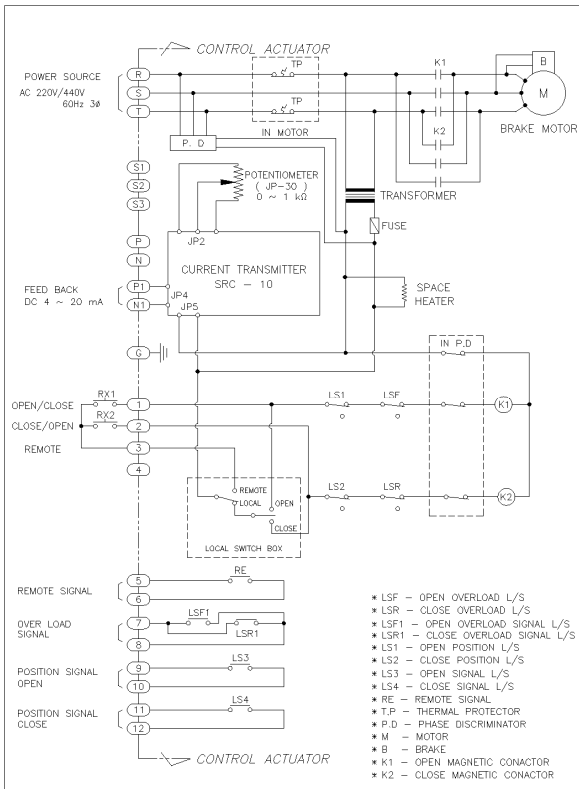

Three phase (More than CA20H)

4-4 For Opening Control (Using Potentiometer)

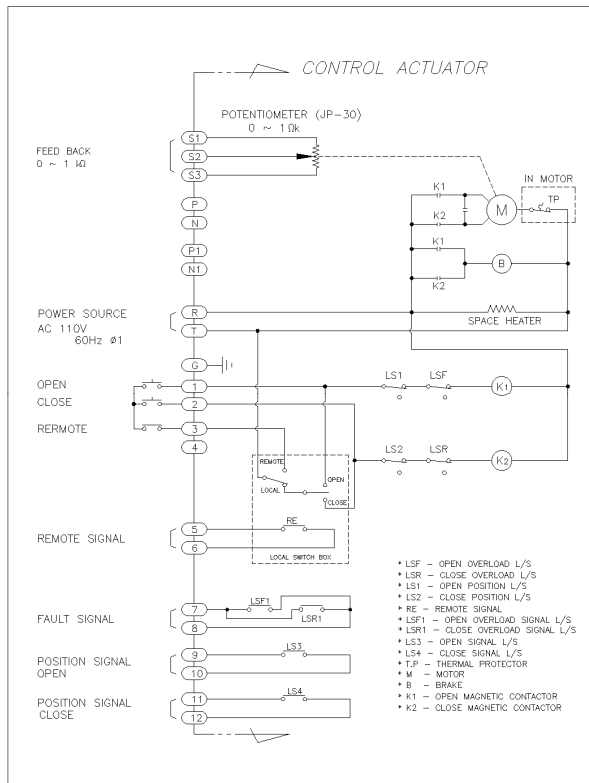

Single phase (Up to CA10H)

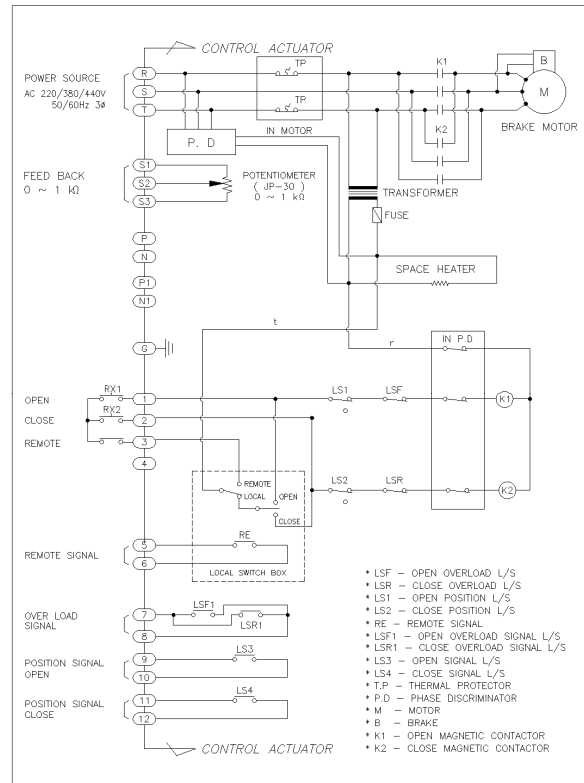

Three phase (Up to CA10H)

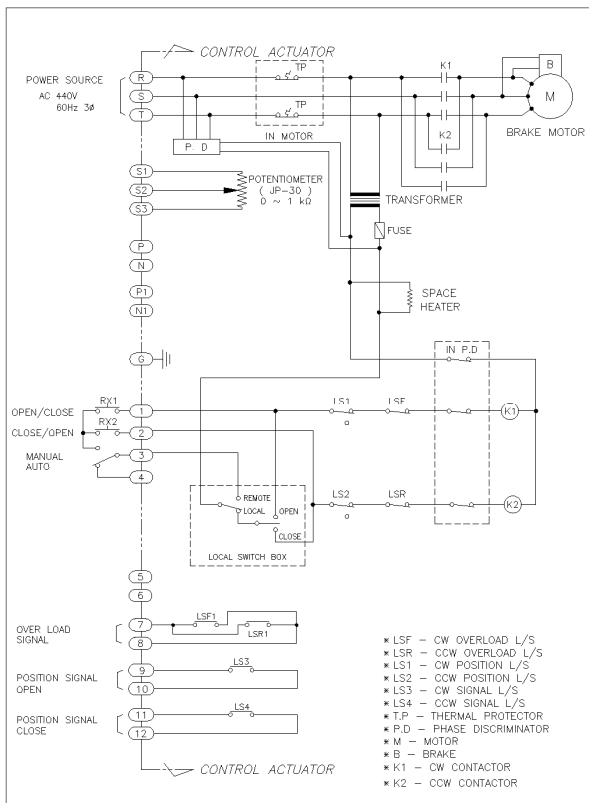

Three phase (More than CA20H)

SEG SHINHWA ENG. Co., Ltd.

Manufacturer information

Company Name : SHIN HWA ENG Co., Ltd

Address : 242 Cheongneungdae-ro (80B -2L), Namdong gu,

Incheon Korea

ZIP CODE : 21695

Tel : 82-32-817-8030

Fax : 82-32-815-8036

E mail : 8030@seg.co.kr

Website : <http://www.seg.co.kr>

COPYRIGHT 2020(C) Shin Hwa Eng Co., Ltd .ALL RIGHTS RESERVED